

# Gas pressure switch C6097

Technical Information · GB  
4 Edition 01.19

- Monitoring of gas and air pressures (positive, negative and differential pressures)
- Switches with falling or rising pressure.
- FM and UL certified:  
With lock-off and hand wheel with "WC/mbar scale"
- EU certified pursuant to EN 1854: Hand wheel with mbar scale



# Contents

Gas pressure switch C6097.....	1	<b>5 Accessories.....</b>	<b>17</b>
Contents .....	2	5.1 Fastening set with screws, U-shape bracket .....	17
<b>1 Application .....</b>	<b>3</b>	5.2 Connecting set .....	17
1.1 Use .....	4	5.3 Restrictor orifice .....	17
1.1.1 CE approved pressure switches .....	4	5.4 Standard socket set.....	18
1.1.2 FM approved and UL listed pressure switches.....	4	5.5 Standard coupler plug .....	18
1.2 Application examples .....	5	5.6 Pilot lamp set, red or blue.....	18
1.2.1 Low gas pressure monitoring .....	5	5.7 LED set, red/green.....	19
1.2.2 Differential pressure monitoring .....	5	5.8 Cover for auto reset .....	19
1.2.3 Systems leak tightness check.....	5	5.9 Cover for manual reset.....	19
1.2.4 Air line with minimum pressure and flow monitoring .....	6	5.10 Weather protection cover .....	20
1.2.5 Low and high gas pressure protection device.....	6	<b>6 Technical data .....</b>	<b>21</b>
<b>2 Certification .....</b>	<b>7</b>	6.1 General.....	21
2.1 EU certified .....	7	6.2 EU certified pressure switches .....	21
2.2 FM approved.....	7	6.3 UL, FM certified pressure switches .....	22
2.3 UL listed .....	7	6.4 Adjusting range, switching hysteresis .....	22
2.4 Overview of product approvals .....	7	6.4.1 CE certified pressure switches.....	22
<b>3 Function.....</b>	<b>8</b>	6.4.2 UL, FM certified pressure switches.....	23
3.1 Vent limiter.....	8	6.5 Dimensions .....	24
3.2 Positive pressure measurement.....	9	6.5.1 EU certified pressure switches.....	24
3.3 Negative pressure measurement.....	9	6.5.2 UL, FM certified pressure switches.....	25
3.4 Differential pressure measurement .....	9	6.6 Converting units .....	26
3.5 Connection diagram.....	11	<b>7 Maintenance cycles.....</b>	<b>26</b>
3.5.1 Blue pilot lamp for 230 V AC or 110/120 V AC.....	11	<b>Feedback.....</b>	<b>27</b>
3.5.2 Red/green pilot LED for 24 V DC/AC or 110 – 230 V AC.....	11	<b>For more information.....</b>	<b>27</b>
3.6 Wiring.....	12		
<b>4 Project planning information .....</b>	<b>13</b>		
4.1 Installation.....	13		
4.2 Ports .....	14		
4.2.1 CE certified pressure switches.....	14		
4.2.2 UL, FM certified pressure switches .....	15		
4.3 Resetting pressure switches with manual reset..	16		



*C6097 with CE approval.  
Hand wheel with mbar scale.  
M16 cable gland for electrical connection.*

*C6097 with UL listing and FM approval.  
Hand wheel with "WC and mbar scale.  
1/2" NPT conduit for electrical connection.  
C6097 can be supplied with lock-off function.*

### **1 Application**

The pressure switch monitors extremely low pressure differentials and triggers switch-on, switch-off or switch-over operations if a set switching point is reached.

The switching point can be adjusted using a hand wheel.

The pressure switch monitors positive and negative gas pressures on various industrial gas and air appliances, such as boiler fan monitoring and differential pressure monitoring in firing, ventilation and air-conditioning systems.

Pressure switch C6097A switches in the event of decreasing pressure, C6097B switches in the event of increasing pressure.

Pressure switches with manual reset lock off after switching.

Pressure switches with an 0.2 mm (0.008") nozzle are supplied with an integrated vent limiter, see page 8 (Vent limiter).

## 1.1 Use

### 1.1.1 CE approved pressure switches

Type	Hand wheel setting/Switching properties	Positive pressure	Negative pressure	Electrical connection
C6097A4110 C6097A4210 C6097A4310 C6097A4410	Hand wheel set to decreasing pressure/ C6097 switches with rising and falling pressure	Gas, air, flue gas or biogas	Air, flue gas	Screw terminals and M16 cable gland

### 1.1.2 FM approved and UL listed pressure switches

Type	Hand wheel setting/Switching point	Positive pressure	Negative pressure	Electrical connection
C6097A3004 C6097A3053 C6097A3079 C6097A3137	Hand wheel set to decreasing pressure/ C6097 switches with rising and falling pressure	Gas, air, flue gas or biogas	Air, flue gas	Screw terminals 1/2" NPT conduit
C6097A3012 C6097A3038 C6097A3095 C6097A3111	Hand wheel set to decreasing pressure/ C6097 switches with falling pressure and locks off	Gas, air, flue gas or biogas	Air, flue gas	Screw terminals and 1/2" NPT conduit
C6097B3002 C6097B3028 C6097B3051	Hand wheel set to increasing pressure/ C6097 switches with rising pressure and locks off	Gas, air, flue gas or biogas	Air, flue gas	Screw terminals 1/2" NPT conduit
C6097B3085 C6097B3101 C6097B3119	Hand wheel set to increasing pressure/ C6097 switches with rising and falling pressure	Gas, air, flue gas or biogas	Air, flue gas	Screw terminals 1/2" NPT conduit

## 1.2 Application examples

### 1.2.1 Low gas pressure monitoring

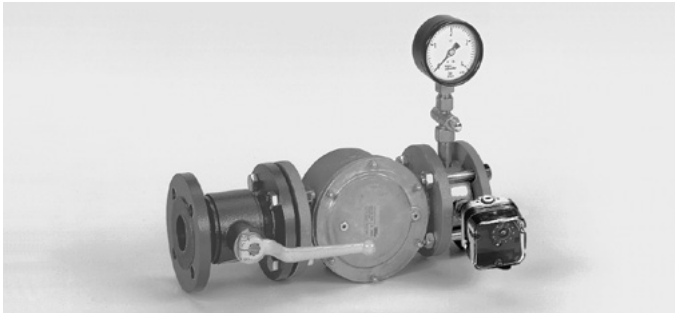

For monitoring the minimum gas inlet pressure

### 1.2.2 Differential pressure monitoring

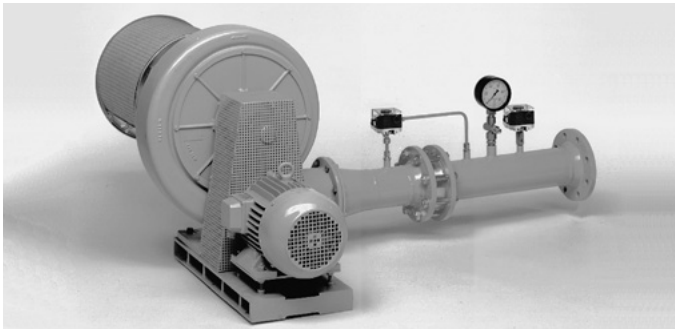

Differential pressure switch for monitoring air filters

### 1.2.3 Systems leak tightness check

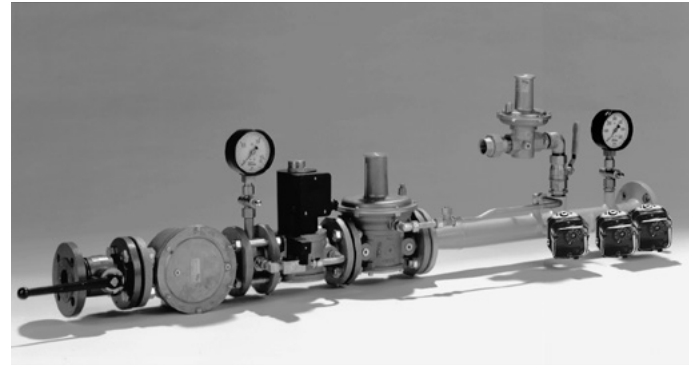

Electronic safety shut-off valve SAV with leak tightness check of downstream devices

## 1.2.4 Air line with minimum pressure and flow monitoring

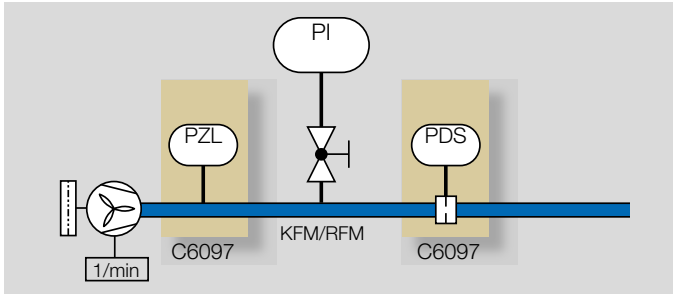

The air flow generated by the fan may be monitored as follows:

The static pressure is monitored by the pressure switch (PZL) as long as it can be demonstrated that the display consequently shows an adequate and secured flow of air, or the pressure switch (PDS) checks the flow of air via the differential pressure on the orifice.

If there is no air pressure supplied or if there is no differential pressure on the orifice, the system will be blocked.

## 1.2.5 Low and high gas pressure protection device

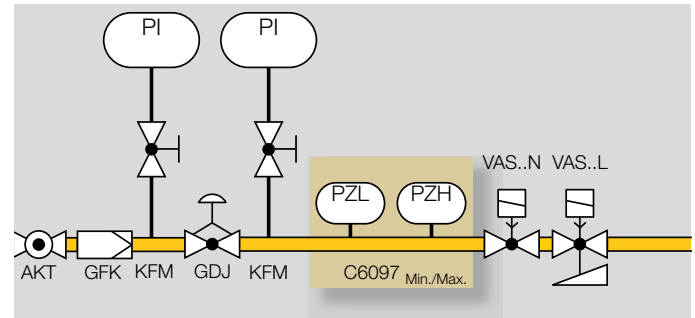

If the pressure is either too low or too high, the min./max. pressure switch (PZL/PZH) switches in order to avoid start-up or to initiate a safety shut-down.

## 2 Certification

Certificates – see Docuthek.

### 2.1 EU certified



- 2014/35/EU (LVD) – Low Voltage Directive
- 2014/30/EU (EMC) – Electromagnetic Compatibility Directive
- (EU) 2016/426 (GAR) – Gas Appliances Regulation
- EN 13611:2015+AC:2016
- EN 1854:2010

### 2.2 FM approved



Factory Mutual Research Class: 3510 Flow and pressure safety switches. Designed for applications pursuant to NFPA 85 and NFPA 86. [www.approvalguide.com](http://www.approvalguide.com)

### 2.3 UL listed

USA and Canada



UL 353 Limit control.

Underwriters Laboratories – [www.ul.com](http://www.ul.com) → Tools (at the bottom of the page) → Online Certifications Directory

### 2.4 Overview of product approvals

Type	EU certified	FM approved	UL listed
C6097A4110	●	-	-
C6097A4210			
C6097A4310			
C6097A4410			
C6097A3004	-	●	●
C6097A3012			
C6097A3038			
C6097A3053			
C6097A3079			
C6097A3095			
C6097A3111			
C6097A3137			
C6097B3002			
C6097B3028			
C6097B3051			
C6097B3085			
C6097B3101			
C6097B3119			

### 3 Function

Pressure switch C6097A switches with falling pressure, C6097B switches with rising pressure.

Once the set switching point is reached, a micro switch is activated in the pressure switch which is designed as a change-over contact.

The switching pressure is adjusted using a hand wheel.

### CE approved pressure switches

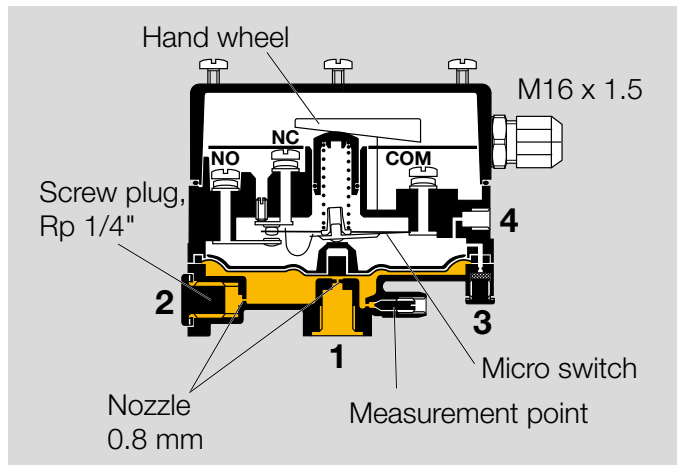

### FM approved and UL listed pressure switches

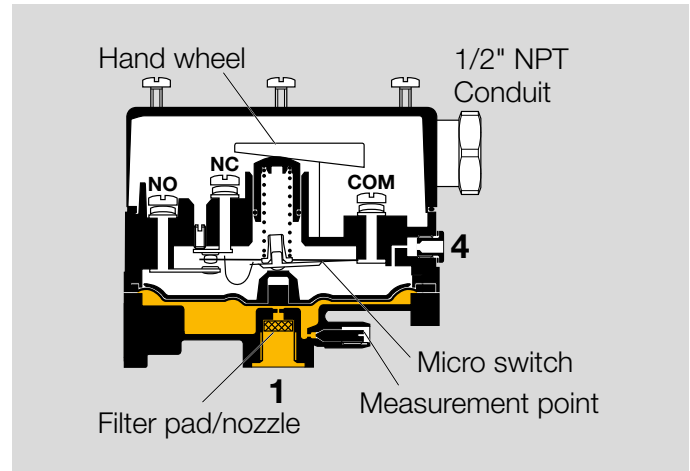

Pressure switches which lock off after switching can only be unlocked with a manual reset, see page 16 (Resetting pressure switches with manual reset).

### 3.1 Vent limiter

The flow on FM approved and UL listed pressure switches is limited by the nozzle. In the event of a diaphragm tear, the escape of gas is limited to less than 1.0 CFH of natural gas, see max. inlet pressure, page 23 (UL, FM certified pressure switches), Adjusting range, switching hysteresis.

### 3.2 Positive pressure measurement

Positive pressure measurement is designed, for example, for checking the fan function or measuring the min./max. gas pressure.

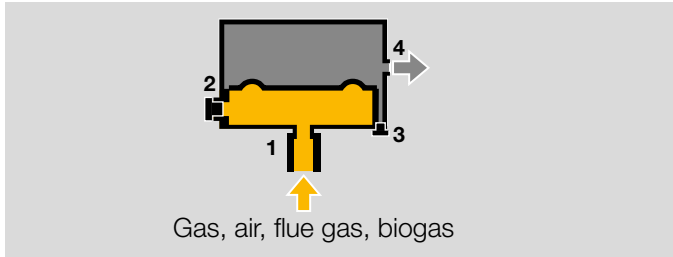

The positive pressure is measured in the lower diaphragm chamber, port **1** (or **2**). The upper diaphragm chamber is ventilated via port **4** (or **3**).

### 3.3 Negative pressure measurement

Negative pressure measurement is designed, for example, for monitoring a suction pressure blower.

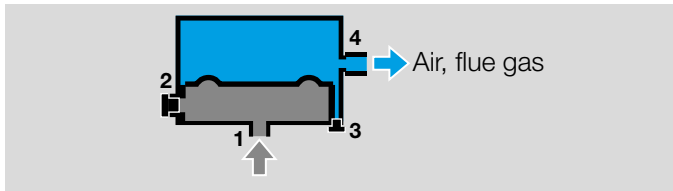

The negative pressure is measured in the upper diaphragm chamber, port **4** (or **3**). The lower diaphragm chamber is ventilated via port **1** (or **2**).

### 3.4 Differential pressure measurement

Differential pressure measurement is designed for safeguarding an air flow rate or for monitoring filters and fans, for example.

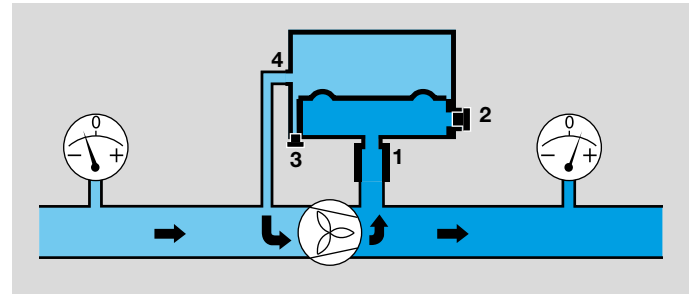
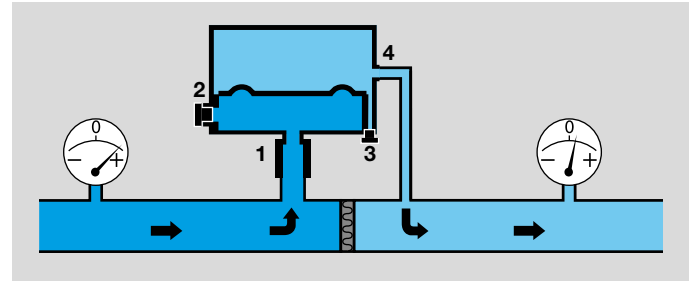

The higher absolute pressure is connected to port **1** (or **2**), and the lower absolute pressure to port **4** (or **3**). The remaining ports must be tightly plugged.



## Function

---

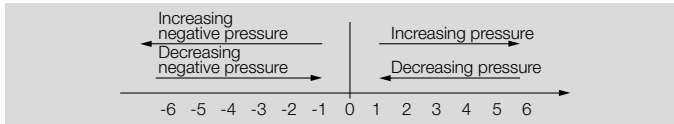

Do not connect port **4** (or **3**) to pipes carrying gas! For further information, see page 14 (Ports).

### 3.5 Connection diagram

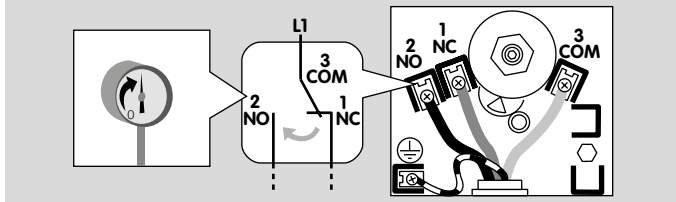

Contacts 3 and 2 close when subject to increasing pressure.

Contacts 1 and 3 close when subject to falling pressure.

On pressure switches that switch with rising pressure:  
The contact switches from NC 1 to NO 2.

On pressure switches that switch with falling pressure:  
The contact switches from NO 2 to NC 1.

#### 3.5.1 Blue pilot lamp for 230 V AC or 110/120 V AC

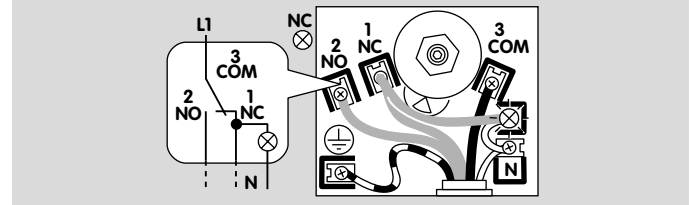
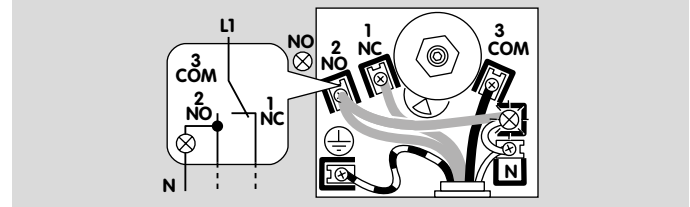

#### 3.5.2 Red/green pilot LED for 24 V DC/AC or 110 – 230 V AC

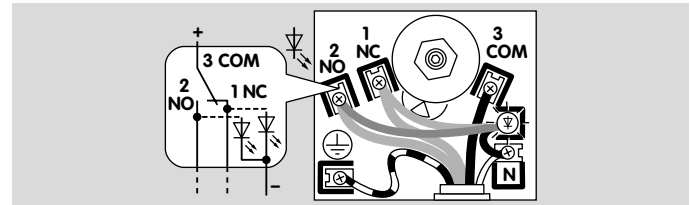

### 3.6 Wiring

When using silicone tubes, only use silicone tubes which have been sufficiently cured. Vapours containing silicone can adversely affect the functioning of electrical contacts. In the case of low switching capacities, such as 24 V, 8 mA, for example, we recommend using an RC module (22  $\Omega$ , 1  $\mu$ F) in air containing silicone or oil.

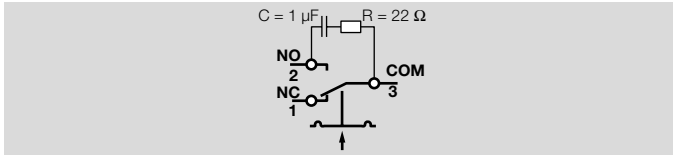

In the case of high humidity or aggressive gas components ( $H_2S$ ), we recommend using a pressure switch with gold contact due to its higher resistance to corrosion. Closed-circuit current monitoring is recommended under difficult operating conditions.

## 4 Project planning information

### 4.1 Installation

Installation in the vertical or horizontal position, or sometimes upside down, preferably with vertical diaphragm.

If installed in a vertical position, the switching point  $p_S$  will correspond to the scale value SK set on the hand wheel. If installed in another position, the switching point  $p_S$  will change and no longer correspond to the scale value SK set on the hand wheel. Switching point  $p_S$  must be checked.

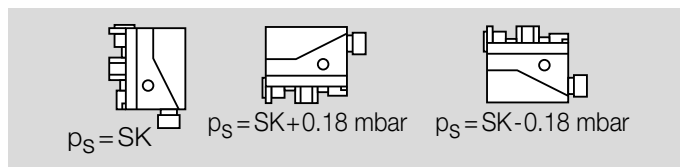

The housing must not be in contact with masonry. Minimum clearance 25 mm (1").

Continuous operation at high temperatures (e.g. maximum ambient temperature) accelerates the ageing of elastomer materials and reduces the service life (please contact manufacturer). Ozone concentrations exceeding  $200 \mu\text{g}/\text{m}^3$  or gases containing more than 0.1 %-by-vol.  $\text{H}_2\text{S}$  accelerate the ageing of elastomer materials and reduce the service life.

Vapours containing silicone can adversely affect the functioning of electrical contacts. When using silicone tubes, only use silicone tubes which have been sufficiently cured.

Condensation must not be allowed to get into the housing (if possible, install pipework with an ascending gradient). Otherwise, there is a risk of icing of condensation at subzero temperatures, the switching point shifting or corrosion in the device which can lead to malfunctions.

When installing outdoors, place the pressure switch in a roofed area and protect from direct sunlight (even IP 65 version).

In case of highly fluctuating pressures, install a restrictor orifice, see page 17 (Restrictor orifice).

## 4.2 Ports

### 4.2.1 CE certified pressure switches

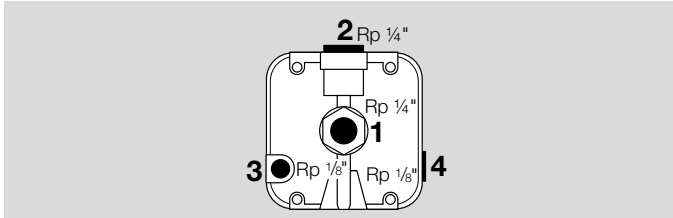

Positive ressure	Connect	Seal	Free*
C6097	1	2	3 or 4
	2	1	3 or 4

Negative ressure	Connect	Seal	Free*
C6097	4	3	1 or 2
	3	4	1 or 2

\* It is recommended that the port which is best protected from water and dirt be left open.

Differential pressure	Connect		Seal
	for the higher absolute pressure	for the lower absolute pressure	
C6097	1 or 2	3 or 4	Seal ports that are not in use

Ports **3** and **4** are connected to the micro switch chamber.

Pipes carrying gas must not be connected to port **3** or **4**!

The port that is best protected against soiling (dust/humidity) is to be left open for ventilation (positive pressure measurement) to the atmosphere.

### 4.2.2 UL, FM certified pressure switches

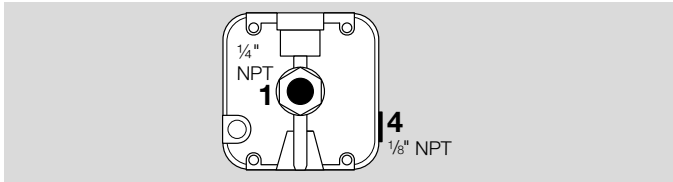

Positive pressure	Connect	Free
C6097	1	4

Negative pressure	Connect	Free
C6097	4	1

Differential pressure	Connect	
	for the higher absolute pressure	for the lower absolute pressure
C6097	1	4

Port **4** is connected to the micro switch chamber.

For this reason, pipes carrying gas must not be connected to port **4**!

If necessary, port **4** (1/8" NPT) can be used to connect the venting line.

A filter pad at port **4** protects the electrical contacts in the pressure switch from dirt particles in the surrounding air or in the medium.

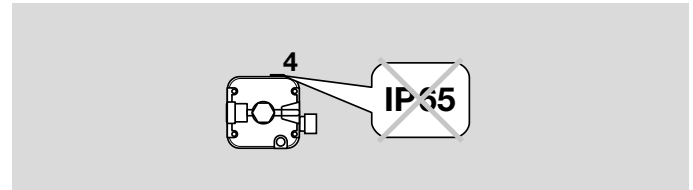

If port **4** is at the top, IP 65 will not be satisfied.

### 4.3 Resetting pressure switches with manual reset

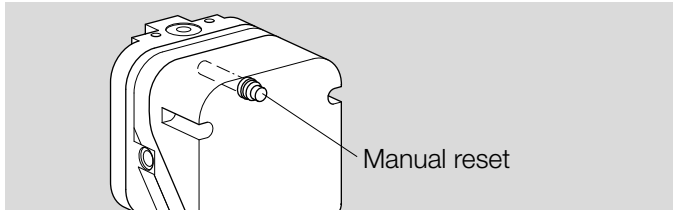

For details of the pressure differential between the switching pressure and possible reset, see page 22 (Adjusting range, switching hysteresis).

C6097A3012, C6097A3038, C6097A3095, C6097A3111 lock off if the pressure drops to the set switching point.

For resetting, the pressure must have risen to at least the set switching point **plus** the pressure differential between the switching pressure and possible reset.

C6097B3002, C6097B3028, C6097B3051 lock off if the pressure rises to the set switching point.

For resetting, the pressure must have dropped to at least the set switching point **minus** the pressure differential between the switching pressure and possible reset.

## 5 Accessories

### 5.1 Fastening set with screws, U-shape bracket

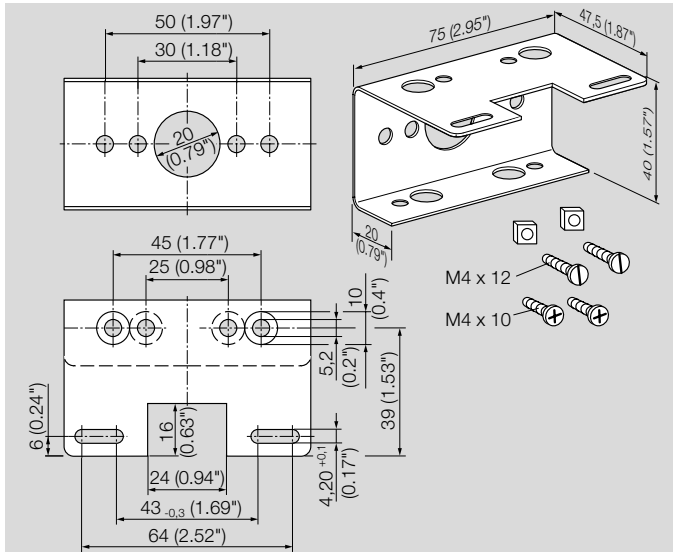

Order No.: 32003042-003/U

### 5.2 Connecting set



For monitoring a minimum and maximum inlet pressure with two pressure switches attached to one another.

Order No.: 32003043-003/U

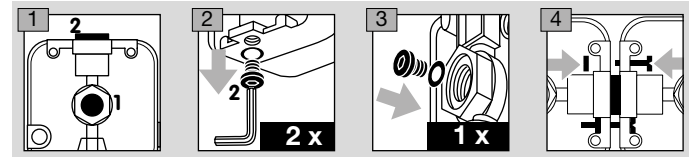

### 5.3 Restrictor orifice

For CE certified pressure switches

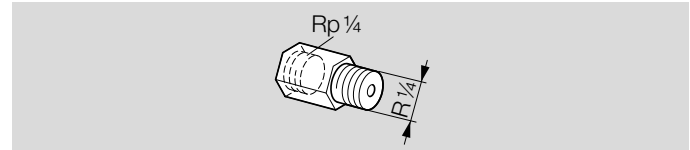

In the case of high pressure fluctuations, we recommend using a restrictor orifice (contains non-ferrous metals):

Hole diameter  $\varnothing$  0.2 mm, Order No.: 32003051-003/U,

Hole diameter  $\varnothing$  0.3 mm, Order No.: 32003052-003/U.

## 5.4 Standard socket set

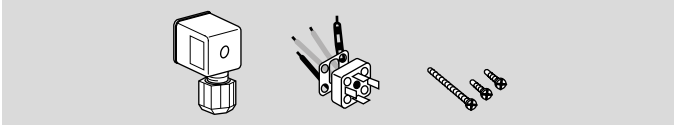

For CE certified pressure switches

Order No.: 32003053-003/U.

For FM, UL certified pressure switches

Order No.: 32003054-003/U.

## 5.5 Standard coupler plug

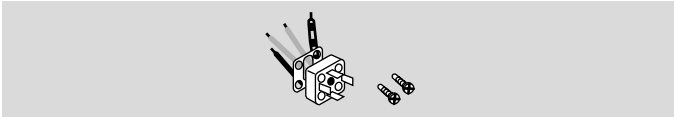

For CE certified pressure switches

Order No.: 32003055-003/U.

For FM, UL certified pressure switches

Order No.: 32003056-003/U.

## 5.6 Pilot lamp set, red or blue

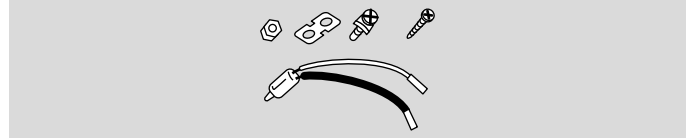

Pilot lamp, red:

110/120 V AC, I = 1.2 mA, Order No.: 32003044-003/U.

230 V AC, I = 0.6 mA, Order No.: 32003046-003/U.

Pilot lamp, blue:

110/120 V AC, I = 1.2 mA, Order No.: 32003045-003/U.

230 V AC, I = 0.6 mA, Order No.: 32003047-003/U.

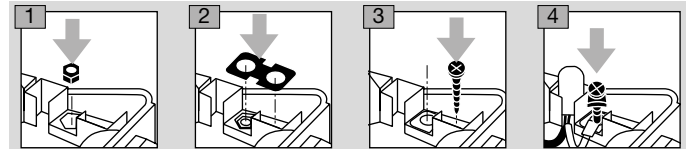

### 5.7 LED set, red/green

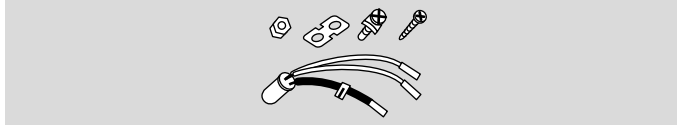

24 V DC, I = 16 mA; 24 V AC, I = 8 mA, Order No.:  
32003048-003/U.

110 – 230 V AC, Order No.: 32003049-003/U.

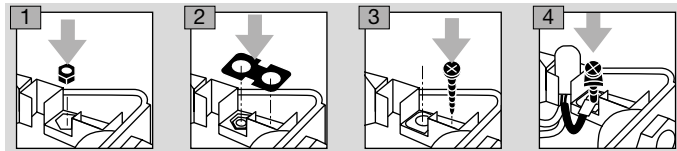

### 5.8 Cover for auto reset

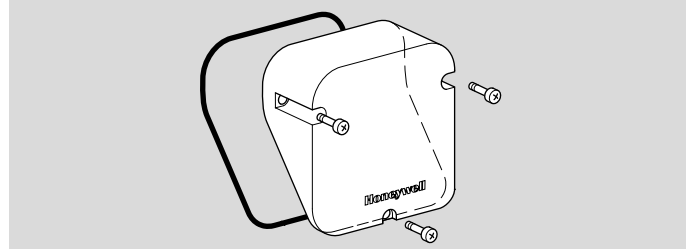

Order No.: 32003040-003/U

### 5.9 Cover for manual reset

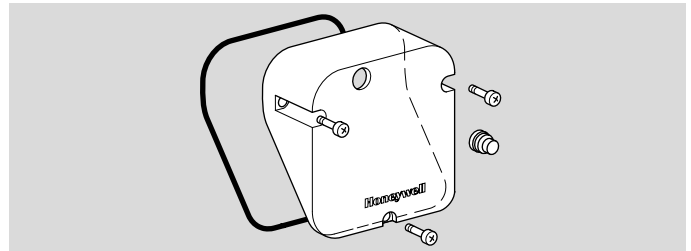

Order No.: 32003041-003/U

## 5.10 Weather protection cover

When the DG is installed outdoors, the weather protection cover provides permanent protection against condensation and weathering of housing parts.

The weather protection cover is made of 1 mm (0,04")-thick stainless steel.

Installation position: vertical with the cable gland pointing downwards.

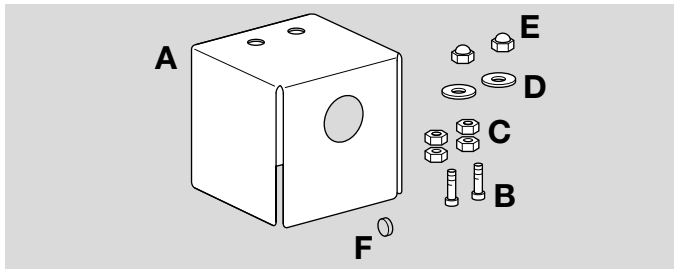

2 M4 x 16 screws with 2 cap nuts.

The enclosed filter pad is designed to protect the open  $\frac{1}{8}$ " port from the ingress of dirt or insects.

Scope of delivery:

**A** 2 x covers, 100 x 100 x 100 mm

**B** 2 x M4 x 16 screws

**C** 4 x nuts

**D** 2 x washers

**E** 2 x cap nuts

**F** 1 x filter pad ( $\frac{1}{8}$ " port)

Order No.: 32003050-003/U.

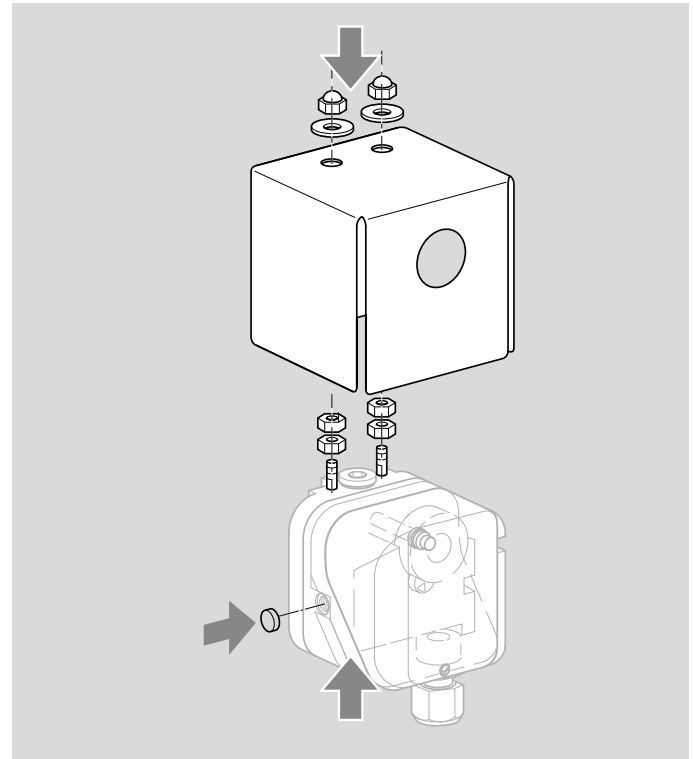

## 6 Technical data

### 6.1 General

Gas type: natural gas, town gas, LPG (gaseous), flue gas, biogas (max. 0.1 %-by-vol. H<sub>2</sub>S) and air.

Max. inlet pressure  $p_{max.}$  = withstand pressure, see page 22 (Adjusting range, switching hysteresis).

Electrical connection type: screw terminals.

Diaphragm pressure switch, silicone-free.

Diaphragm: NBR.

Housing: glass fibre reinforced PBT plastic with low gas release.

Lower housing section: AlSi 12.

Enclosure: IP 65, safety class: 1.

Max. medium and ambient temperatures, see page 21 (EU certified pressure switches) and page 22 (UL, FM certified pressure switches).

Storage and transport temperature:  
-20 to +40°C (-4 to +104°F).

Long-term use in the upper ambient temperature range accelerates the ageing of the elastomer materials and reduces the service life (please contact manufacturer).

The set switching point may palpably change in media and ambient temperatures below -22°F (-30 °C).

Recommended tightening torque:

Component	Tightening torque [Ncm]
Cover screws	65
M16 x 1.5 cable gland	50
½" NPT conduit	170 (15 lb")
Rp ⅛ pipe connection, aluminium	250
Rp ¼ (¼" NPT) gas connection	1300
Rp ⅛ air connection, switch housing	250
Clamping terminal screws	80
T15 test point screw	150

Weight:

270 to 320 g (9.5 to 11.3 oz) depending on equipment.

### 6.2 EU certified pressure switches

Max. test pressure for testing the entire system:  
temporarily < 15 minutes 2 bar (29 psig).

Switching capacity:

U = 24 – 250 V AC,

I = 0.05 – 5 A at  $\cos \varphi = 1$ ,

I = 0.05 – 1 A at  $\cos \varphi = 0.6$ .

Maximum medium and ambient temperatures:  
-20 to +80°C (-4 to +176°F),

Line entrance:

M16 x 1.5 cable gland,

clamping range: diameters of 4 to 10 mm.

Cable diameter: AWG 24 to AWG 13,  
0.5 to 1.8 mm (0.02 to 0.07").



## 6.3 UL, FM certified pressure switches

Switching capacity:

$U = 24 - 240 \text{ V AC}$ ,

$I = \text{max. } 5 \text{ A at } \cos \varphi = 1$ ,

$I = \text{max. } 0.5 \text{ A at } \cos \varphi = 0.6$ .

Maximum medium and ambient temperatures:

$-40 \text{ to } +60^\circ\text{C}$  ( $-40 \text{ to } +140^\circ\text{F}$ ).

Line entrance:

½" NPT conduit.

Cable diameter: AWG 24 to AWG 13,

0.02 to 0.07" (0.5 to 1.8 mm).

## 6.4 Adjusting range, switching hysteresis

### 6.4.1 CE certified pressure switches

Type	Adjusting range* mbar	Mean switching differential at min. and max. setting mbar	Max. inlet pressure $p_{\text{max.}}$ = withstand pressure mbar	Difference between switching pressure and possible reset mbar	Deviation from the switching point during testing pursuant to EN 1854	
					Gas pressure switch	Air pressure switch
C6097A4110	1 - 10	0.25 - 0.4	500	-	± 15%	± 15%
C6097A4210	2.5 - 50	0.8 - 1.5	500	-	± 15%	± 15%
C6097A4310	30 - 150	3 - 5	600	-	± 15%	± 15%
C6097A4410	100 - 500	8 - 17	600	-	± 15%	± 15%

\* Adjusting tolerance = ± 15% of the scale value.

Switching properties, see page 4 (Use).



### 6.4.2 UL, FM certified pressure switches

Type	Adjusting range* "WC (mbar)	Mean switching differential at min. and max. setting "WC (mbar)	Max. inlet pressure		Lock-off	Difference between switching pressure and possible reset "WC (mbar)	Medium	NPT connection	Switching properties at setpoint value	
			with	without						
			venting line							
			psi (mbar)	psi (mbar)						
C6097A3004	0.4 - 4 (1 - 10)	0.1 - 0.16 (0.25 - 0.4)	8.5 (600)	7 (480)	No	-	Air/gas	1/4"	NO-to-COM connection is interrupted if the pressure drops	
C6097A3012	1 - 20 (2.5 - 50)	-	8.5 (600)	7 (480)	Yes	0.4 - 0.8 (1 - 2)	Air/gas	1/4"		
C6097A3038	12 - 60 (30 - 150)	-	8.5 (600)	7 (480)	Yes	0.8 - 4.8 (2 - 12)	Air/gas	1/4"		
C6097A3053	1 - 20 (2.5 - 50)	0.3 - 0.6 (0.75 - 1.5)	8.5 (600)	7 (480)	No	-	Air/gas	1/4"		
C6097A3079	12 - 60 (30 - 150)	1.2 - 2 (3 - 5)	8.5 (600)	7 (480)	No	-	Air/gas	1/4"		
C6097A3095	0.4 - 4 (1 - 10)	-	8.5 (600)	7 (480)	Yes	0.16 - 0.4 (0.4 - 1)	Air/gas	1/4"		
C6097A3111	40 - 200 (100 - 500)	-	8.5 (600)	7 (480)	Yes	2 - 7.2 (5 - 18)	Air/gas	1/4"		
C6097A3137	40 - 200 (100 - 500)	3.2 - 6.8 (8 - 17)	8.5 (600)	7 (480)	No	-	Air/gas	1/4"		
C6097B3002	12 - 60 (30 - 150)	-	8.5 (600)	7 (480)	Yes	0.8 - 4.8 (2 - 12)	Air/gas	1/4"		NC-to-COM connection is interrupted if the pressure rises
C6097B3028	1 - 20 (2.5 - 50)	-	8.5 (600)		Yes	0.4 - 0.8 (1 - 2)	Air/gas	1/4"		
C6097B3051	40 - 200 (100 - 500)	-	8.5 (600)		Yes	2 - 7.2 (5 - 18)	Air/gas	1/4"		
C6097B3085	12 - 60 (30 - 150)	1.2 - 2 (3 - 5)			No	-	Air/gas	1/4"		
C6097B3101	40 - 200 (100 - 500)	3.2 - 6.8 (8 - 17)			No	-	Air/gas	1/4"		
C6097B3119	1 - 20 (2.5 - 50)	0.3 - 0.6 (0.75 - 1.5)			No	-	Air/gas	1/4"		

\* Adjusting tolerance = ± 15% of the scale value.

For further information, see page 4 (Use).

## 6.5 Dimensions

### 6.5.1 EU certified pressure switches

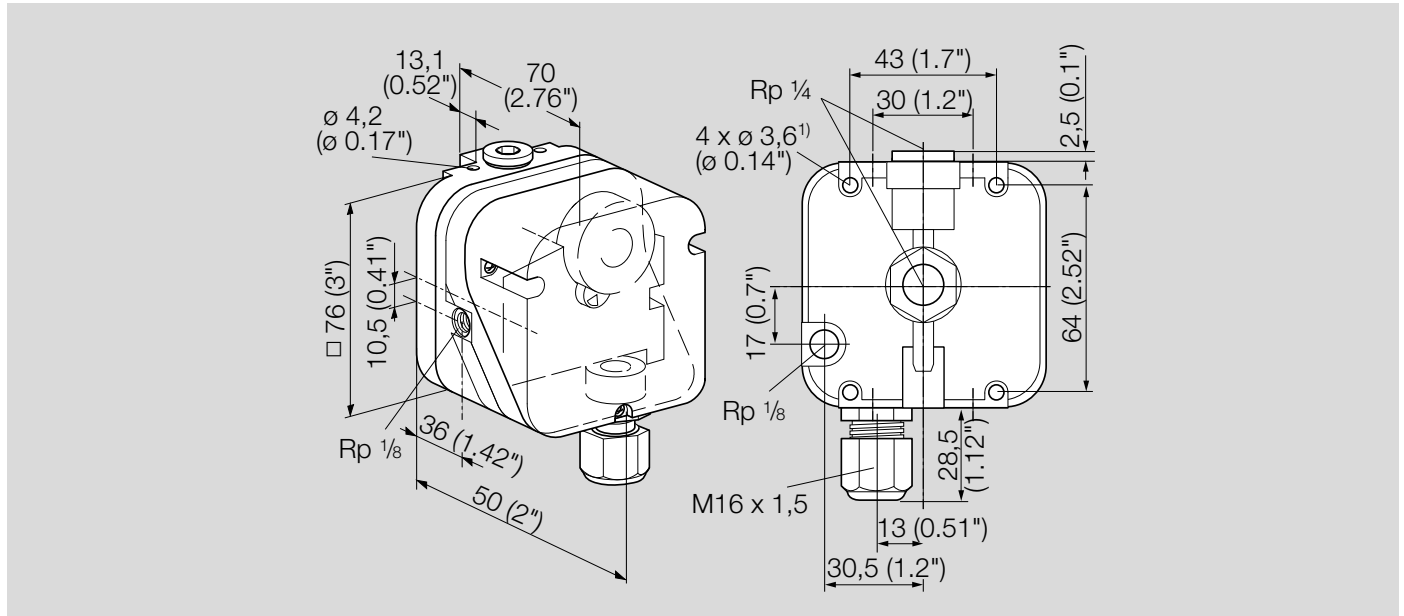

<sup>1)</sup> Holes 10 mm (0.4") deep, for self-tapping screws.

### 6.5.2 UL, FM certified pressure switches

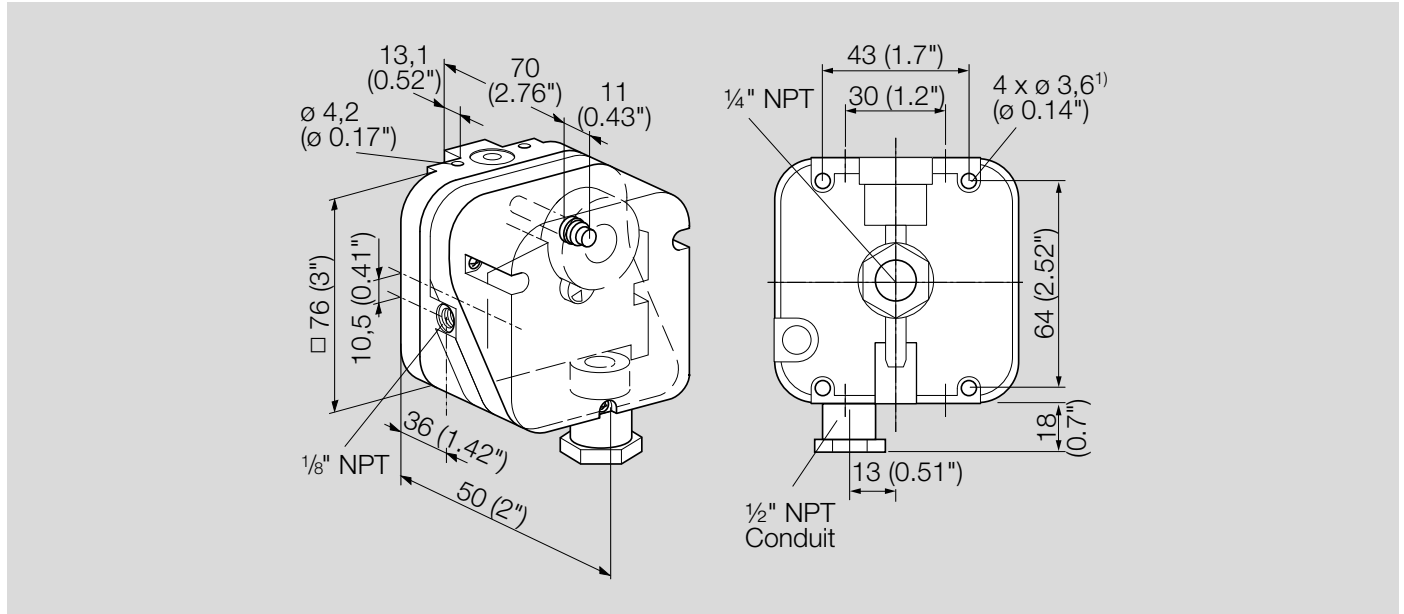

<sup>1)</sup> Holes 10 mm (0.4") deep, for self-tapping screws.

---

## **7 Maintenance cycles**

At least once per annum, at least twice per annum for biogas.

